

5. Gimbal Parameter Adjustment

The product defaults to stabilization mode. If you need to adjust parameters, please go to the HEQUAV official website to download the Assistant software and firmware.

If you cannot install after downloading, please pay attention to whether the computer has a driver installed or the Assistant software is blacklisted by the computer antivirus software.

Note: The Assistant software is only available on WINDOWS system.

6. Assistant Usage Instructions

Open the G-PORT Assistant folder, find exe , and double-click to open the Assistant software.

> G-PORT Assistant

名称	修改日期	类型	大小
ffmpeg	2025-03-12 10:25	文件夹	
HEQ heq-integration-All-0325(1).exe	2025-03-12 10:41	应用程序	20,423KB

Select "G-PORT" in the Assistant software homepage to enter the G-Port parameter page

Connect to the computer using a Type-C data cable, select the correct port, set the baud rate to "921600", and click the "Open" button to establish the connection.

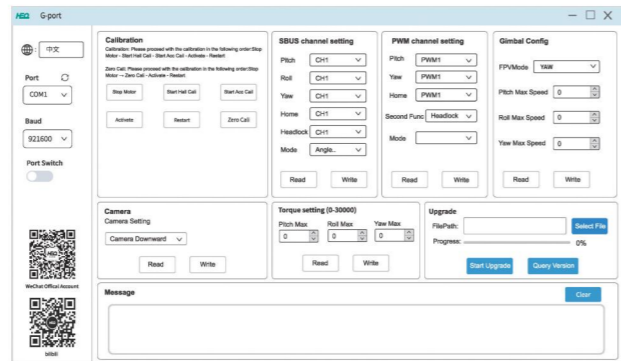

Please note that after each adjustment of the parameters, click "Write", and then click "Restart" for the settings to take effect.

Please search "HEQUAV" on social media

You can view the detailed parameter adjustment tutorial on HEQUAV official social media.

7. Compatible Camera Types

DJI Version
DJI O3 Air Unit、 DJI O4 Air Unit Pro、 DJI O4 Air Unit
CADDX Version
Walksnail Moonlight Kit
Walksnail Avatar HD Pro Kit
Walksnail Avatar HD Kit V2
CADDXFPV Polar Starlight Vista Kit
CADDXFPV Nebula Pro Vista Kit
Walksnail Avatar HD Kit V2 (Dual Antennas Version)
Walksnail Avatar HD Pro Kit (Dual Antennas Version)
RunCam Link Phoenix HD Kit
RunCam Link Wasp Kit
RunCam Link Night Eagle Kit

Please search "HEQUAV" on social media



If this document is updated, without further notice



G-PORT

Quick Start Guide

V1.2

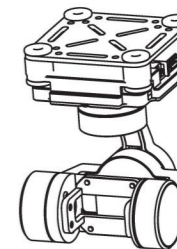

Shenzhen HEQ Intelligent Technology Co.,Ltd.

1.Product Introduction

G-port is a 3-axis gimbal component developed by HEQ for FPV enthusiasts and fixed-wing drone hobbyists. G-port boasts high stability and supports both upright and inverted installations. It is compatible with DJI O3/O4/O4Pro/Caddx, supports three inputs: mavlink, sbus, and pwm. It is adaptable to various flight platforms. This allows users to quickly assemble their personalized gimbal camera.

Tips: This gimbal cannot support DJI O3/O4/O4Pro/Caddx camera at the same time. Please contact us to determine which model needs to be adapted before purchasing.

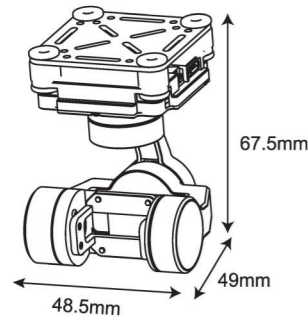

2.Parameter List

Gimbal Parameters	
Axes	Mechanical three-axis
Weight	DJI O3 & Caddx Version 67g
	DJI O4 Air Unit Version 75g
	DJI O4 Air Unit Pro Version 71g
Gimbal Angles	Pitch:-135° to 45°
	Yaw: -135° to 135°
	Roll: -45° to 45°
Supported Control Modes	sbus 、 pwm 、 mavlink
Supported Camera Types	DJI O3/O4/O4Pro /Caddx (Other types can be customized)
Supply Voltage	12V-18V

3.Installation Dimensions(mm)

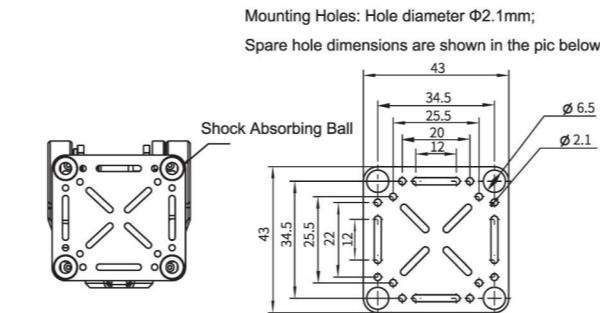

DJI O3 & Caddx Version

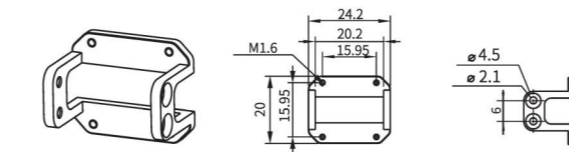

DJI O4 Air Unit Pro Version

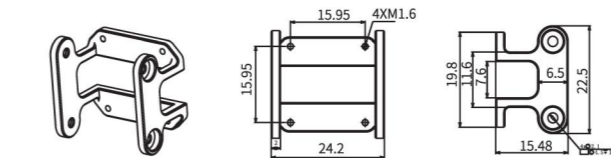

DJI O4 Air Unit Version

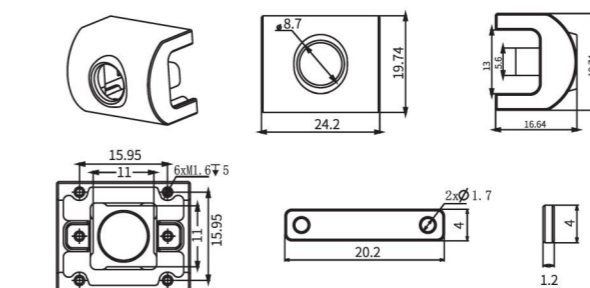

4.G-Port Interface Definitions

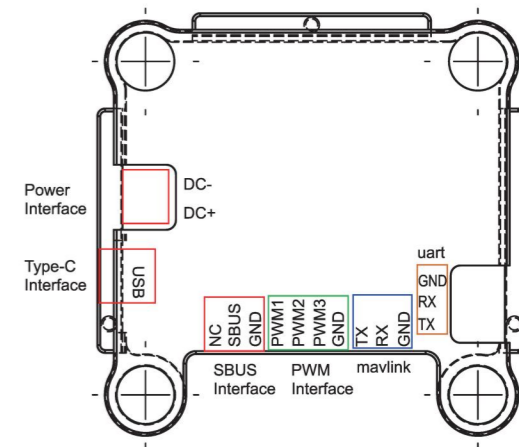

5、云台调参

产品默认为增稳模式,如有调参需要请前往HEQUAV官网
<https://www.hequavtech.com>下载上位机软件及固件。

如下载后无法安装,请注意电脑是否安装有驱动程序或上位机被电脑杀毒软件列入黑名单

注意:上位机软件仅限在WINDOWS系统使用

6、上位机使用说明

打开G-PORT上位机文件夹,找到exe文件,双击打开上位机软件。

G-PORT上位机			
名称	修改日期	类型	大小
ffmpeg	2025-03-12 10:25	文件夹	
HEQ heq-integration-All-0325(1).exe	2025-03-12 10:41	应用程序	20,423KB

在上位机主页型号中选择“G-PORT”,进入G-Port调参页面。

使用type-c数据线与电脑连接,选择正确的端口号,设置波特率为921600,点击“打开”按钮即可进行连接。



请注意每次调整完参数点击“写入”后,需要再点击“重启”,设置才能生效

关注禾启智能B站,解锁详细调参介绍视频



7、适配相机

大疆版本
DJI O3 Air Unit、DJI O4 Air Unit Pro、DJI O4 Air Unit
蜗牛CADDX 版本
Walksnail Moonlight Kit
Walksnail Avatar HD Pro Kit
Walksnail Avatar HD Kit V2
CADDXFPV Polar Starlight Vista Kit
CADDXFPV Nebula Pro Vista Kit
Walksnail Avatar HD Kit V2 (Dual Antennas Version)
Walksnail Avatar HD Pro Kit (Dual Antennas Version)
RunCam Link Phoenix HD Kit
RunCam Link Wasp Kit
RunCam Link Night Eagle Kit

本文档如有更新,恕不另行通知

您可以在官方网站查询最新版本 <https://www.hequavtech.com>

关注禾启智能B站,解锁更多教学视频



G-PORT

快速入门指南

V1.2

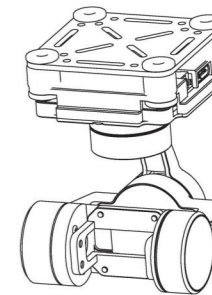

深圳市禾启智能科技有限公司

1、产品简介

G-port是HEQ针对广大固定翼FPV及穿越机爱好者开发的一款三轴云台组件。G-port稳定性高,支持正置、倒置安装。可安装大疆O3, O4系列或者蜗牛CADDX,支持sbus, pwm, mavlink 三种输入,兼容多种飞行平台,让玩家快速搭建属于自己的个性化云台相机。

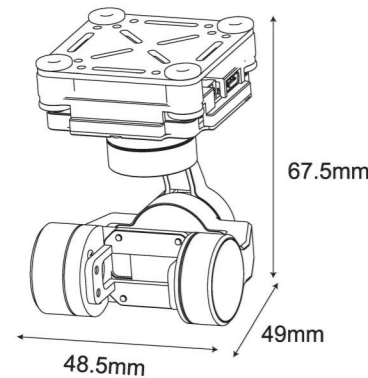

2、产品参数

云台参数	
轴数	机械三轴
重量	DJI O3 & Caddx 版本 67g DJI O4 Air Unit 版本 75g DJI O4 Air Unit Pro 版本 71g
云台角度	俯仰: -135°至 45° 航向: -135°至 135° 横滚: -45°至 45°
支持控制方式	sbus、pwm、mavlink
支持相机类型	DJI O3/O4/O4Pro /Caddx (其他类型可定制)
供电范围	12v~18v

3、安装尺寸 (单位:mm)

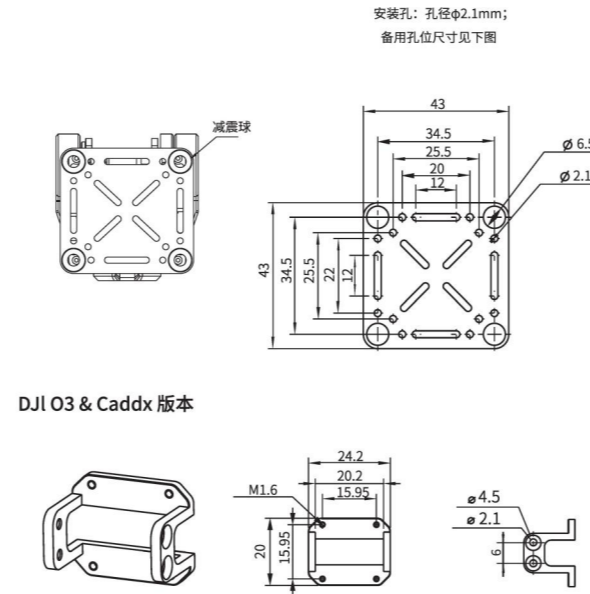

DJI O4 Air Unit Pro 版本

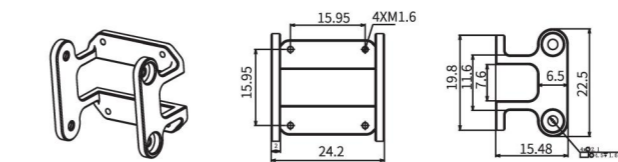

DJI O4 Air Unit 版本

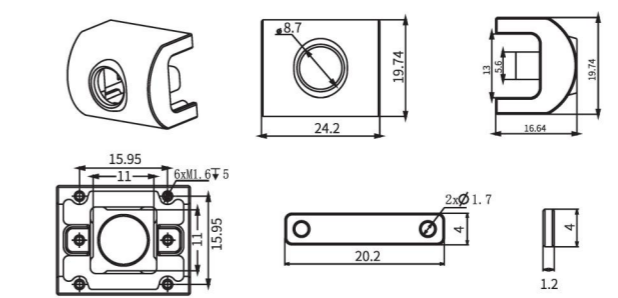

4、G-Port接口定义

