

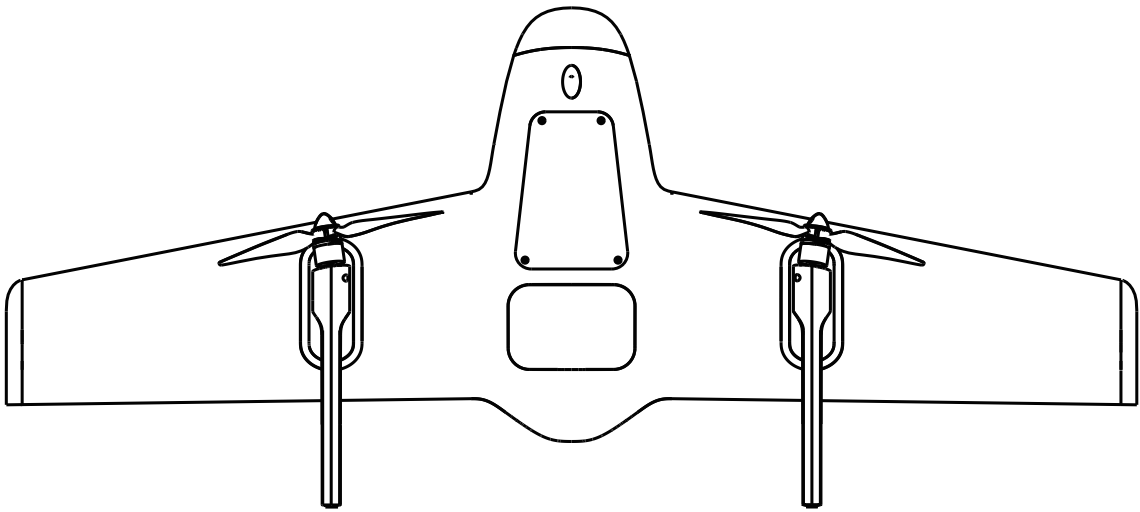

# SWAN K1 PRO PNP 快速入门手册

V1.0



## PNP简介

Swan K1 PRO PNP版本是专为无人机DIY玩家打造的,玩家可以充分利用手上闲置的模块,打造专属于自己的无人机。Swan K1 PRO PNP版本具备垂直起降功能,无飞行场地限制。整机模块化设计,结构部件少,除4个电机外无其他运动部件,拆卸部分无需额外工具。

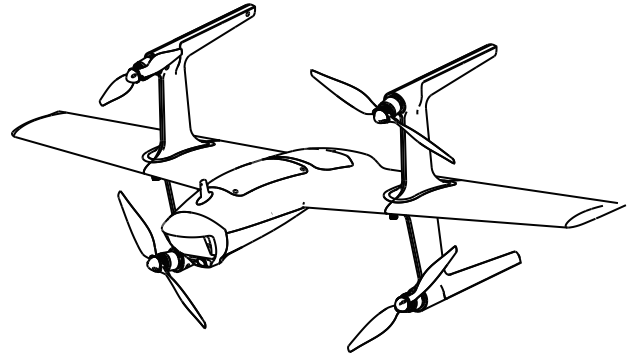

## Swan K1 PRO PNP组成

Swan K1 PRO PNP主要由机翼、机臂、机身、螺旋桨、配重块等部件组成。其中机身内还含有**飞控、电调、空速计、GPS、WiFi模块**。

## Swan K1 PRO PNP的接线图如下

WIFI/DATA LINK MODEL

RC RECEIVER

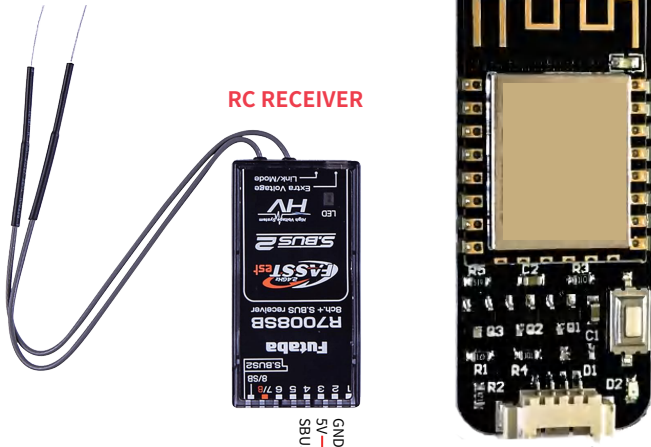

TO AIRSPEED SENSOR  
空速计

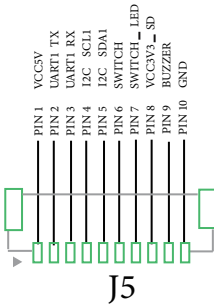

J4

J7

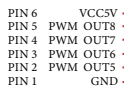
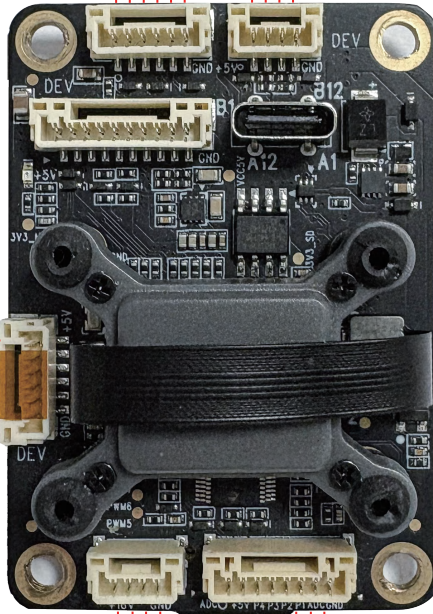

J9

J11

J3

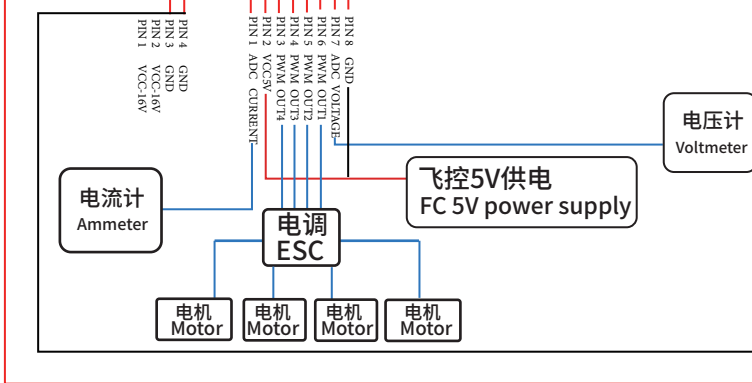

电压计  
Voltmeter

飞控5V供电  
FC 5V power supply

电流计  
Ammeter

电调  
ESC

电机  
Motor

电机  
Motor

电机  
Motor

电机  
Motor

模拟图传  
ANALOG VIDEO TRANSMISSION

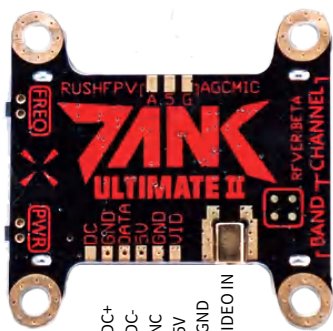

模拟摄像头  
ANALOG CAMERA

MAVLINK TO OSD

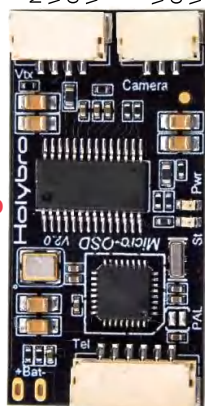

大疆FPV数字图传系统  
DJI FPV DIGITAL IMAGE TRANSMISSION SYSTEM

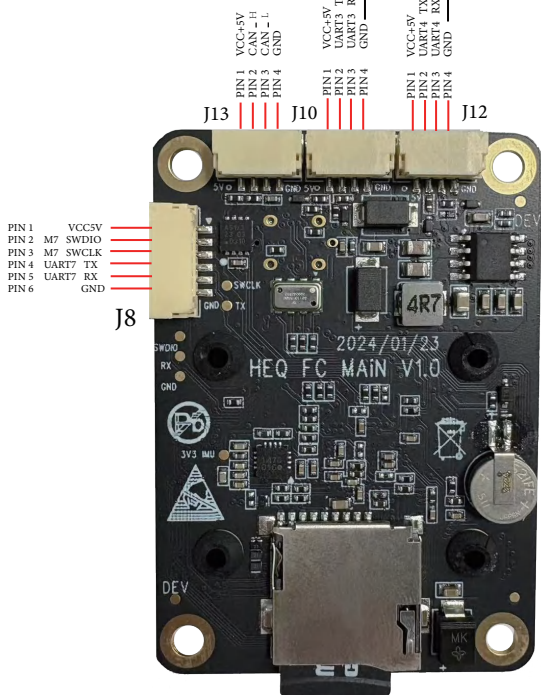

TIPS

J10 可输出常规MAVLINK数据经OSD转换模块转换后输入至常规模拟图传进行图像叠加显示

J12 可直接输出可适配DJI 数字图传系统的OSD数据

## Swan K1 PRO PNP的参数

翼展:1.1m

空机重量:1kg

飞行时间:50-60mins (使用4s 5500mAh以上锂电池或者HEQ官方电池的情况下)

航程:35-40km

最大起飞重量:2.2kg

最大飞行高度:500m

抗风等级:5级

螺旋桨:9060

推荐电池:4s LIPO 5500mAh 电池 (HEQ官方电池 适配电池舱即可, 加进机身后不超过最大起飞重量)

电池舱尺寸:7.5cm\*3.5cm\*6.5cm

适配运动相机:GoPro5\6\7\8;DJI action1\2

支持遥控器协议:SBUS

调参接口:内置WiFi模块 (用户可用手机版本QGC连接飞机进行调试)

支持遥控器通道数量:7通道以上

支持图传:模拟图传/数字图传

对外供电电压:16.8v

一键起飞:支持

智能返航:支持

故障保护:支持

## WiFi模块规格

(机体内部会内置WIFI模块或者常规数传电台, 具体以收到实物为准, 如后续有更新, 不另行通知。)

WIFI网络名:Drone

WIFI密码:12345678

IP地址:192.168.4.1

子网掩码:255.255.255.0

网关:192.168.4.1

端口号:6789

串口波特率:57600

通讯协议:TCP

工作电压:4V-9V DC(推荐5V)

## 其他

### 飞控兼容性：

飞控兼容PX4固件，支持SIYI/云卓等主流厂商链路产品（可按照HEQFLY app进行飞行体验）

### 飞控配置：

请注意，SWAN K1 PRO PNP飞控上的插座均需适配GH1.25型号插头

### 电源插头型号：

SWAN K1 PRO PNP版本使用的电源插头型号为 XT60

### 飞行高度和距离：

SWAN K1 PRO的飞行高度和距离可以在地面站中自定义地理围栏的限制，而实际飞行的效果由用户的遥控和图传设备的能力决定

### FPV功能及图传：

如果您想继续体验FPV功能，则需要单独购买并安装模拟或高清图传设备，安装方案可参考[Swan K1 PRO PNP的接线图](#)。

## SWAN K1 PRO PNP 飞控系统多重安全保护

1 低电压保护

2 智能返航

3 危险姿态保护

4 失速保护

5 失控保护

6 地理围栏

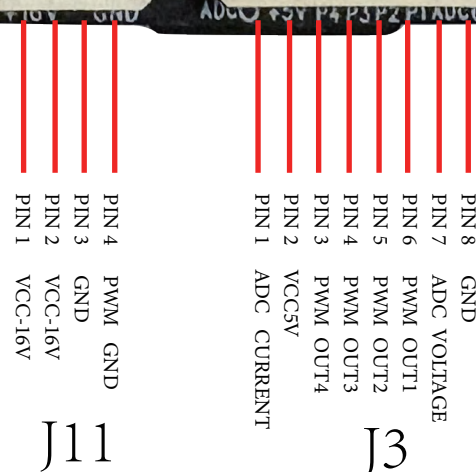
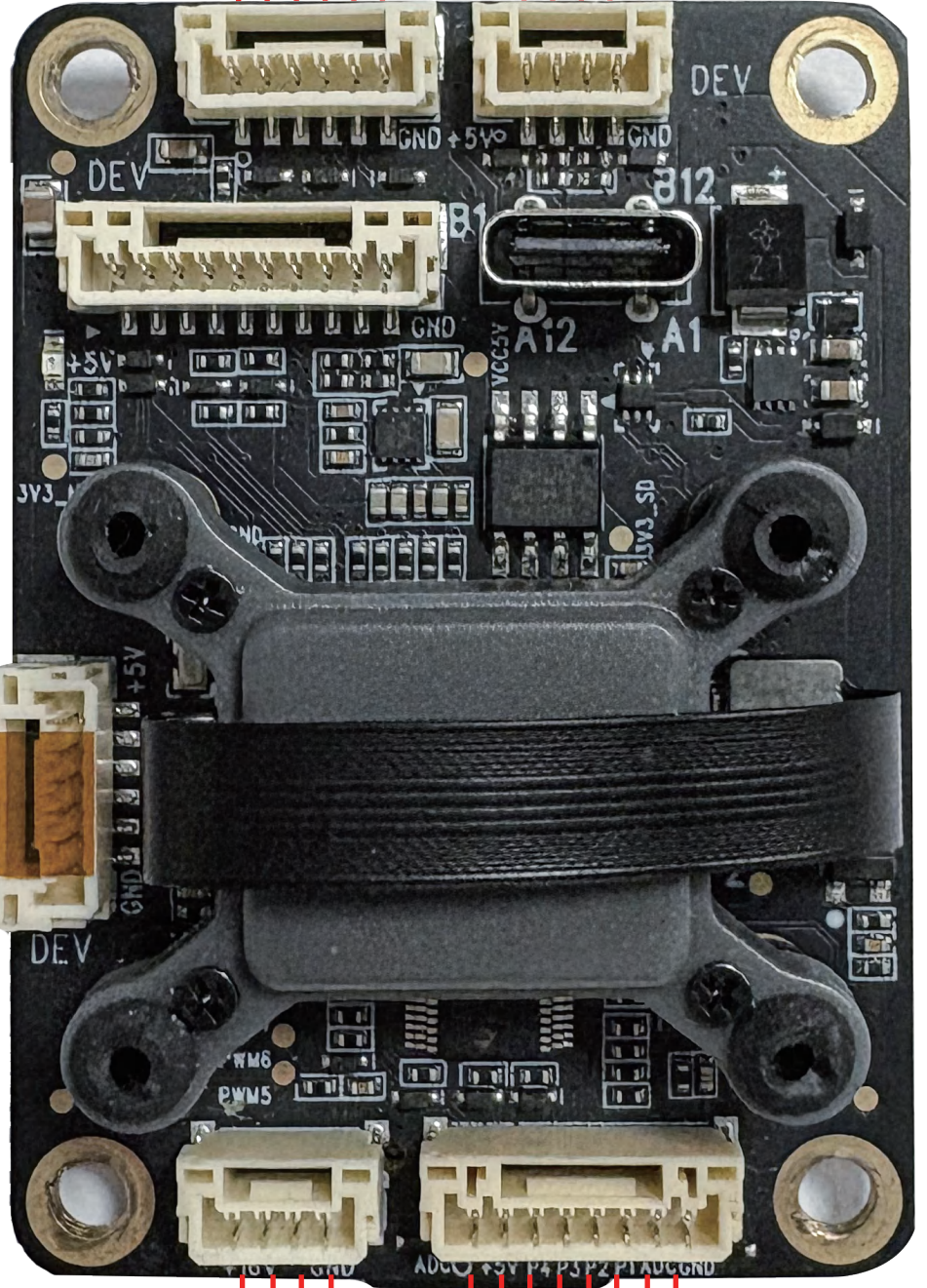
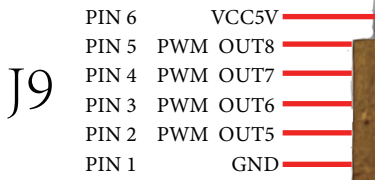
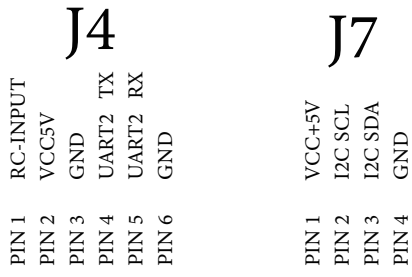
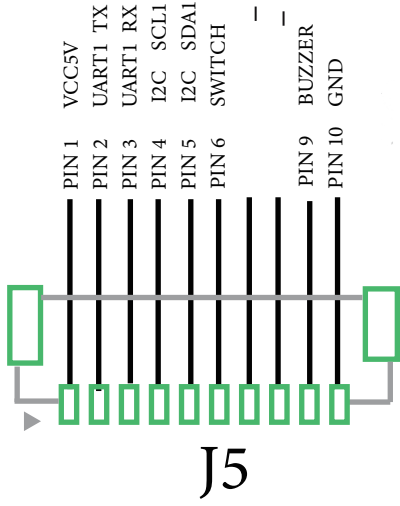

J13

J10

J12

VCC+5V  
CAN\_H  
CAN\_L  
GND

VCC+5V  
UART3 TX  
UART3 RX  
GND

VCC+5V  
UART4 TX  
UART4 RX  
GND

PIN 1  
PIN 2  
PIN 3  
PIN 4

PIN 1  
PIN 2  
PIN 3  
PIN 4

PIN 1  
PIN 2  
PIN 3  
PIN 4

J8

PIN 1 VCC5V  
PIN 2 M7 SWDIO  
PIN 3 M7 SWCLK  
PIN 4 UART7 TX  
PIN 5 UART7 RX  
PIN 6 GND

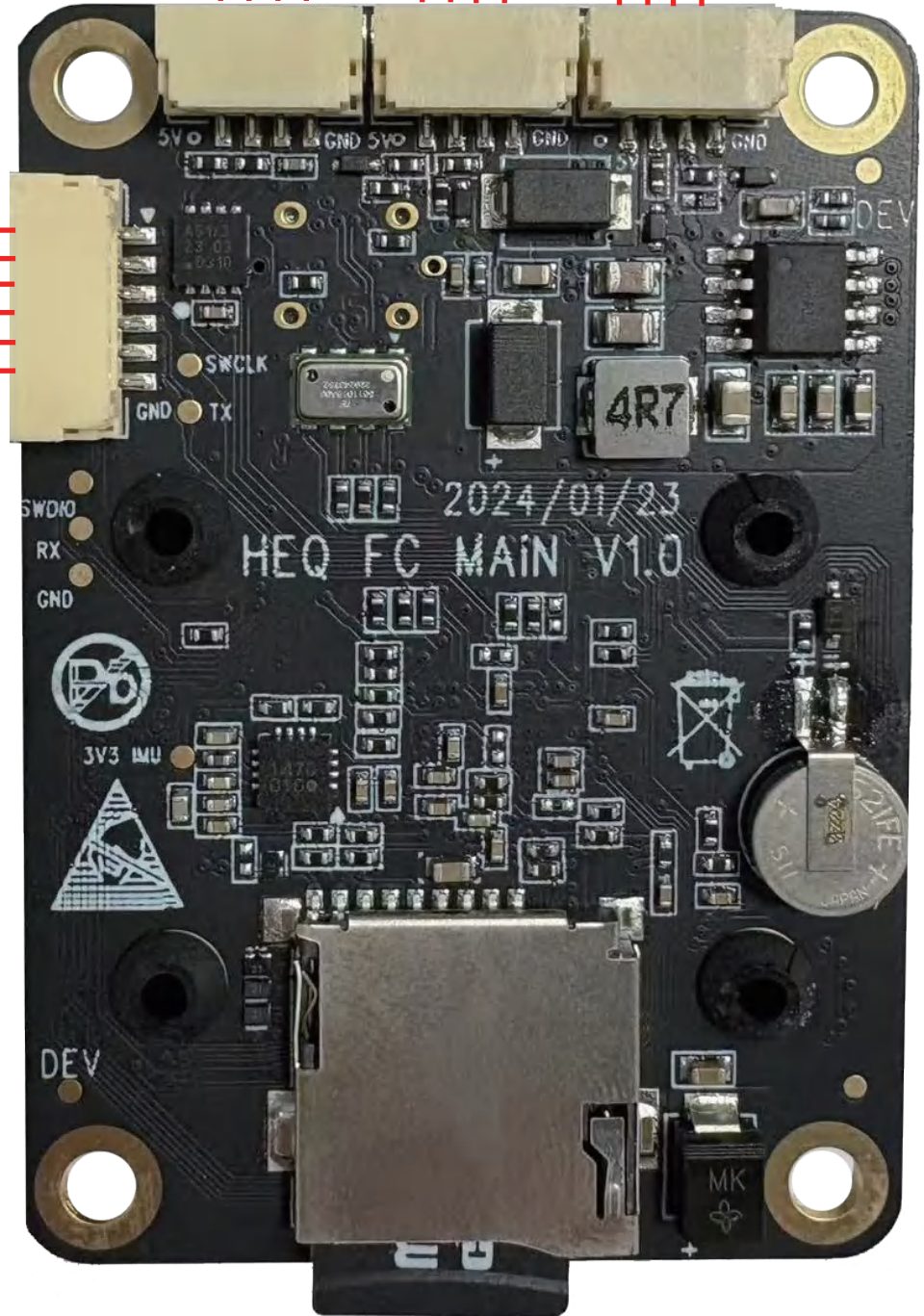

## 飞行指南

### 1. 遥控器

目前仅支持SBUS协议，建议使用7通道以上的遥控器，以充分发挥PNP无人机的功能。我们的PNP是有固定翼和旋翼的切换功能，可以在遥控器进行模式切换和姿态切换设置。（详细请看“禾启智能”bilibili账号的视频教程）。可使用QGC APP（建议在电脑或者手机上使用QGC，平板中使用可能会导致参数显示不全）上设置遥控通道（通道建议如下图）

|                     |                        | 通道Channel |
|---------------------|------------------------|-----------|
|                     | 横滚Roll                 | 1         |
|                     | 俯仰Pitch                | 2         |
|                     | 油门Throttle             | 3         |
|                     | 航向Yaw                  | 4         |
| 模式切换 Mode switch    | 定高/位置Altitude/Position | 5         |
| 姿态切换Attitude switch | 旋翼/固定翼Rotor/Fixed-wing | 7         |
|                     | 返航Return               | 8         |

### 2. 校准

飞行器起飞前，并在QGC APP上对加速度计、陀螺仪、地平线、空速计和罗盘进行校准，空速绝对值大于5需要重新校准，若更换地点需要重新校准磁罗盘，不更换地点环境则不需要。

### 3. WiFi连接

#### (1) 打开QGC APP

注意：QGC软件建议在我们的官网的下载中心下载专用版本（下载中心→无舵面飞行平台→选择Swan K1 Pro PNP→选择电脑端版本/手机端版本）：<https://www.hequavtech.com/downloads?name=Download+Center&navIndex=4>



(2) 连接无人机内置模块 (请注意打开手机的wifi)



(3) 返回QGC app



(4) 点击第三个选项



(5) 打开通讯连接, 点击TCP选项



(6) 勾选开始时自动连接, 并点击确认



(7) 返回QGC界面, 完成连接

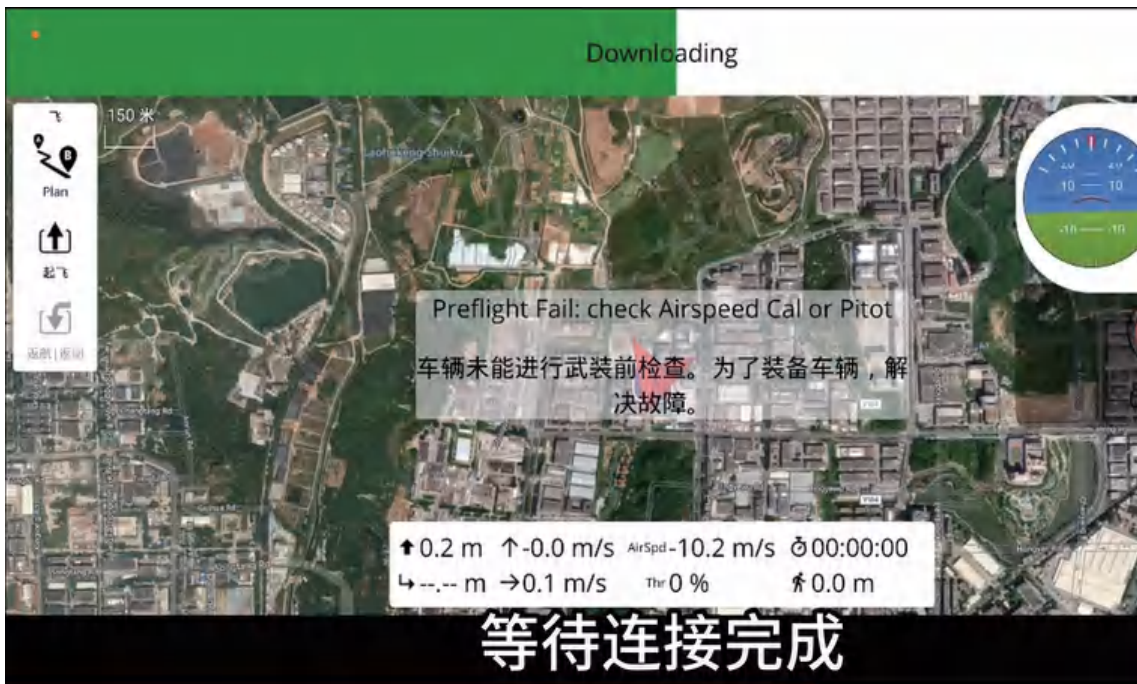

## 飞行前检查

1. 无人机摇杆拨到位置模式, 为了确保安全, 建议垂直起飞到20米以上再切换固定翼模式。
3. 无人机和遥控器电量充足。
4. 飞行前已连接WiFi并加载完地图。
5. GPS信号 $\geq$ 9颗卫星。

## 注意事项

1. 在起飞和降落时, 确保无人机周围没有障碍物, 以免发生碰撞事故。
2. 在飞行过程中, 遵守相关的飞行规定, 在合法区域飞行, 确保飞行安全。
3. 飞行时, 注意观察无人机的飞行姿态和飞行高度, 以确保飞行稳定性。
4. 请勿在人群、树林、机场、火车站、建筑群和室内飞行。

本文档如有更新, 恕不另行通知。

您可以在禾启智能官方网站<https://www.hequavtech.com/>查询最新版本



# SWAN K1 PRO PNP Quick Start Guide

V1.0

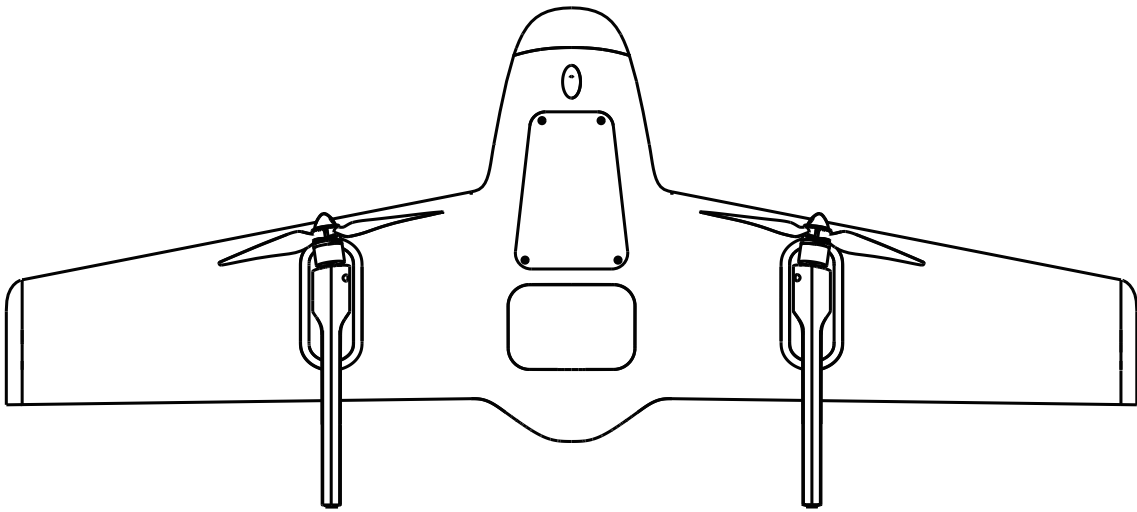

## PNP Introduction

Swan K1 PRO PNP version is specially designed for drone DIY players. Players can make full use of idle modules to build their own drone. Swan K1 PRO PNP version has vertical take-off and landing function and has no flight field restrictions. The whole machine has a modular design with few structural parts. There are no other moving parts except 4 motors, and no additional tools are required for disassembly.

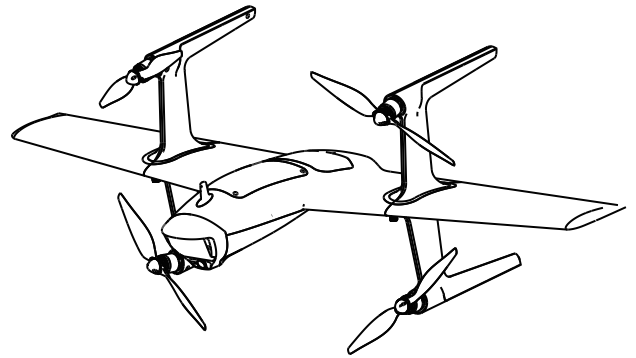

## Swan K1 PRO PNP Composition

Swan K1 PRO PNP is mainly composed of wings, arms, fuselage, propellers, counterweights and other parts. The fuselage also contains flight control, ESC, airspeed meter, GPS, and WiFi modules.

## Swan K1 PRO PNP Wiring Diagram Is As Follows

WIFI/DATA LINK MODEL

RC RECEIVER

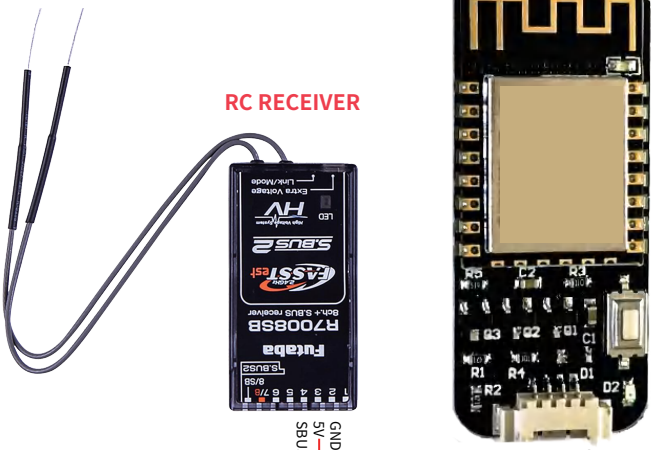

TO AIRSPEED SENSOR

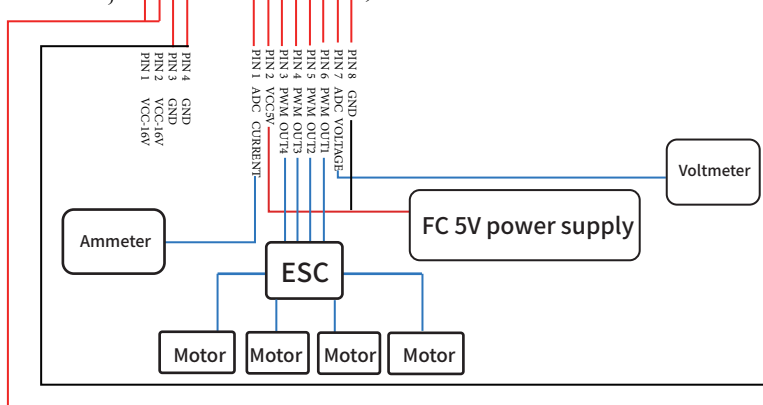
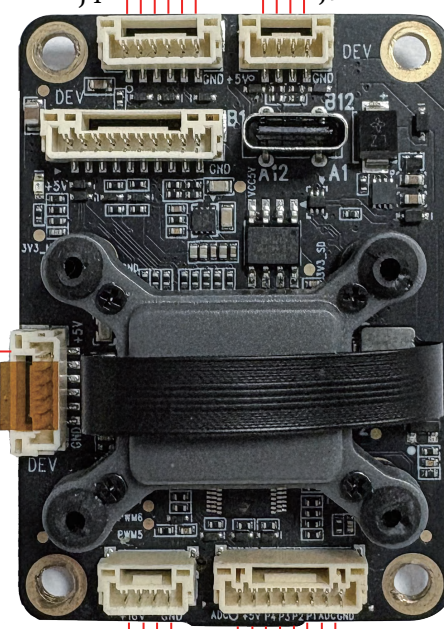
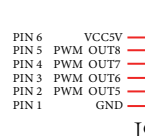
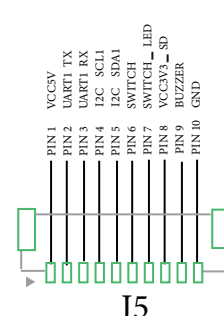

## ANALOG VIDEO TRANSMISSION

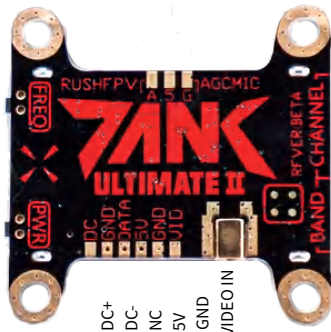

ANALOG CAMERA

## MAVLINK TO OSD



DJI FPV DIGITAL IMAGE TRANSMISSION SYSTEM

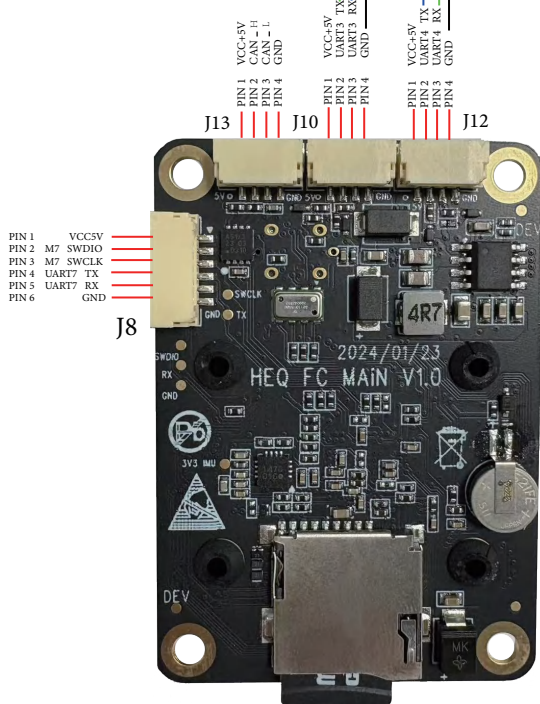

### TIPS

J10 can output regular MAVLINK data, which is converted by the OSD conversion module and then input into the regular analog image transmission for image overlay display

J12 can directly output OSD data that can be adapted to the DJI digital image transmission system

## Swan K1 PRO PNP Parameters

**Wingspan:** 1.1m

**Empty weight:** 1kg

**Flight time:** 50-60mins (using 4s 5500mAh lithium battery or HEQ official battery)

**Range:** 35-40km

**Maximum take-off weight:** 2.2kg

**Maximum flight altitude:** 500m

**Wind resistance:** Level 5

**Propeller:** 9060

**Recommended battery:** 4s LIPO 5500mAh battery (HEQ official battery, or compatible battery compartment, which does not exceed the maximum take-off weight after being added to the fuselage)

**Battery compartment size:** 7.5cm\*3.5cm\*6.5cm

**Compatible sports cameras:** GoPro5\6\7\8; DJI action1\2

**Supported remote control protocol:** SBUS

**Parameter adjustment interface:** built-in WiFi module (users can use the mobile phone QGC version to connect to the aircraft for debugging)

**Supported remote control channels:** 7 channels or more

**Supported image transmission:** analog image transmission/digital image transmission

**External power supply voltage:** 16.8v

**One-key takeoff:** supported

**Intelligent return:** supported

**Fault protection:** supported

## Wifi Module Specifications

(The drone body will have a built-in WiFi module or a conventional data transmission radio. The specific specifications are subject to the actual product received. If there are any subsequent updates, we will not notify you separately.)

WiFi network name: Drone

WiFi password: 12345678

IP address: 192.168.4.1

Subnet mask: 255.255.255.0

Gateway: 192.168.4.1

Port number: 6789

Serial port baud rate: 57600

Communication protocol: TCP

Operating voltage: 4V-9V DC (5V recommended)

## Others

### **Flight Control Compatibility:**

The flight control is compatible with PX4 firmware and supports link products from mainstream manufacturers such as SIYI/skydroid. (flight experience can be performed according to the HEQFLY app).

### **Flight Control Configuration:**

Please note that the sockets on the SWAN K1 PRO PNP flight control must be adapted to the GH1.25 model plug.

### **Power Plug Model:**

For convenience, the power plug model used by the SWAN K1 PRO PNP version is XT60.

### **Flight Altitude And Distance:**

The flight altitude and distance of the SWAN K1 PRO can be customized with geo-fence restrictions in the ground station, and the actual flight effect is determined by the user's remote control and image transmission device capabilities.

### **FPV Function And Image Transmission:**

If you want to continue to experience the FPV function, you need to purchase and install analog or high-definition image transmission equipment separately. For the installation plan, please refer to the wiring diagram of the Swan K1 PRO PNP.

## SWAN K1 PRO PNP Flight Control System Multiple Safety Protections

- 1 Low Voltage Protection
- 2 Intelligent Return Home
- 3 Dangerous Attitude Protection
- 4 Stall Protection
- 5 Lose Control Protection
- 6 Geographical Fencing

# Flight Control

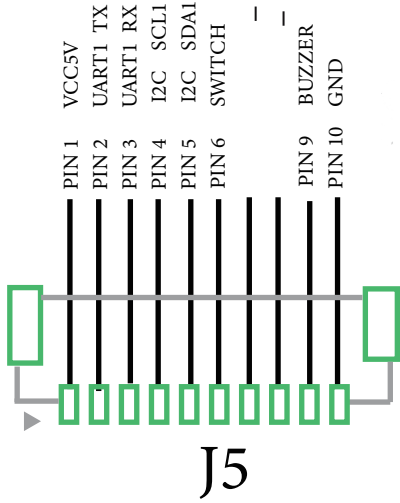

J9

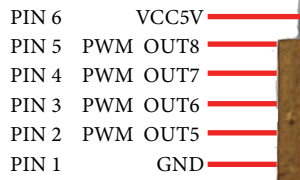

J4

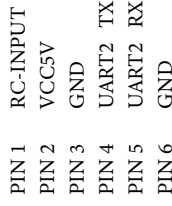

J7

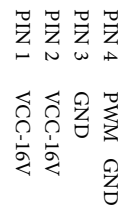
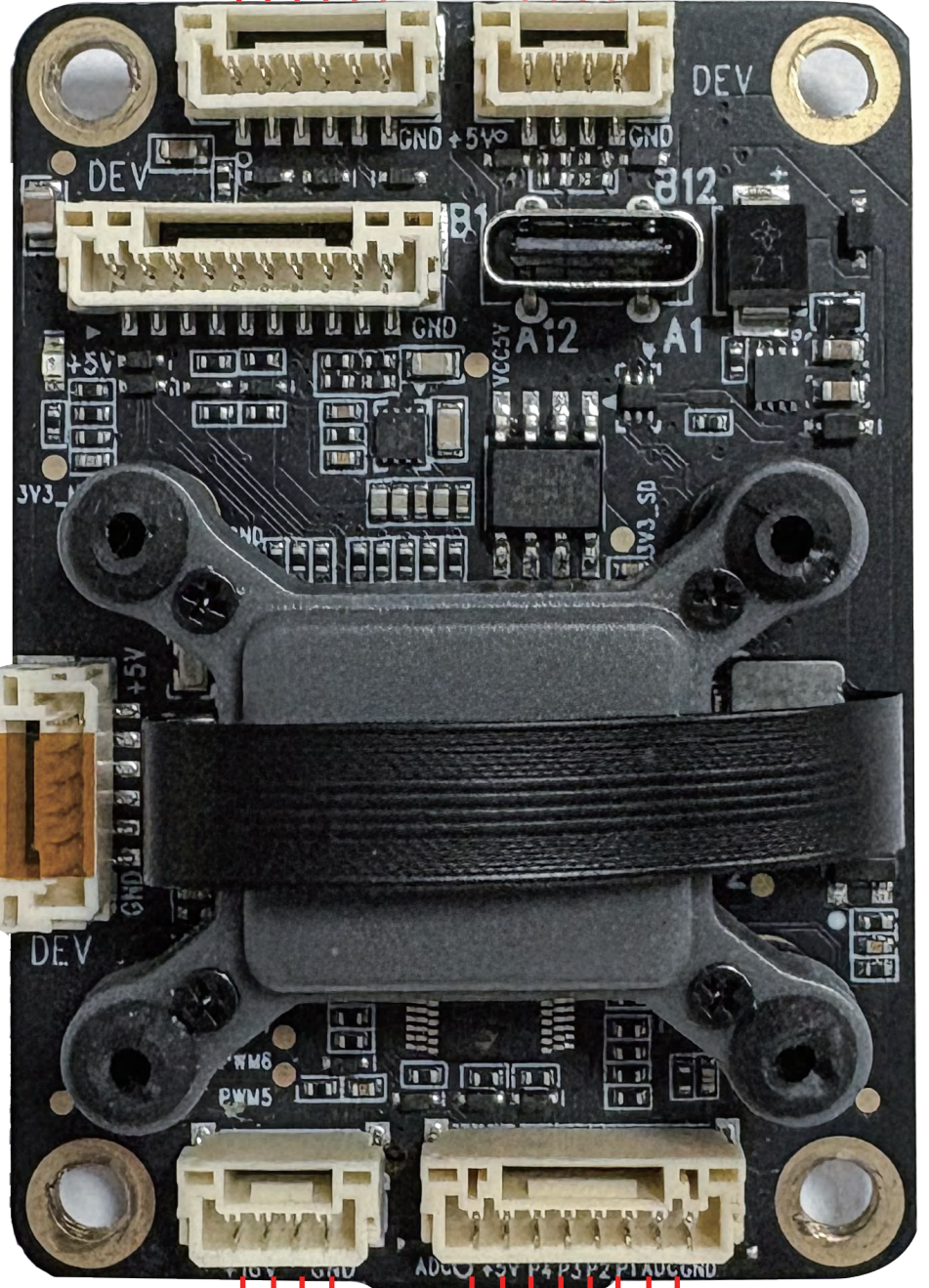
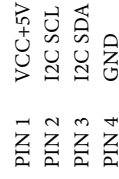

J11

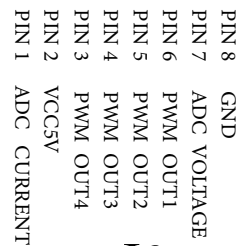

J3

J13

J10

J12

VCC+5V  
CAN\_H  
CAN\_L  
GND

VCC+5V  
UART3 TX  
UART3 RX  
GND

VCC+5V  
UART4 TX  
UART4 RX  
GND

PIN 1  
PIN 2  
PIN 3  
PIN 4

PIN 1  
PIN 2  
PIN 3  
PIN 4

PIN 1  
PIN 2  
PIN 3  
PIN 4

J8

PIN 1 VCC5V  
PIN 2 M7 SWDIO  
PIN 3 M7 SWCLK  
PIN 4 UART7 TX  
PIN 5 UART7 RX  
PIN 6 GND

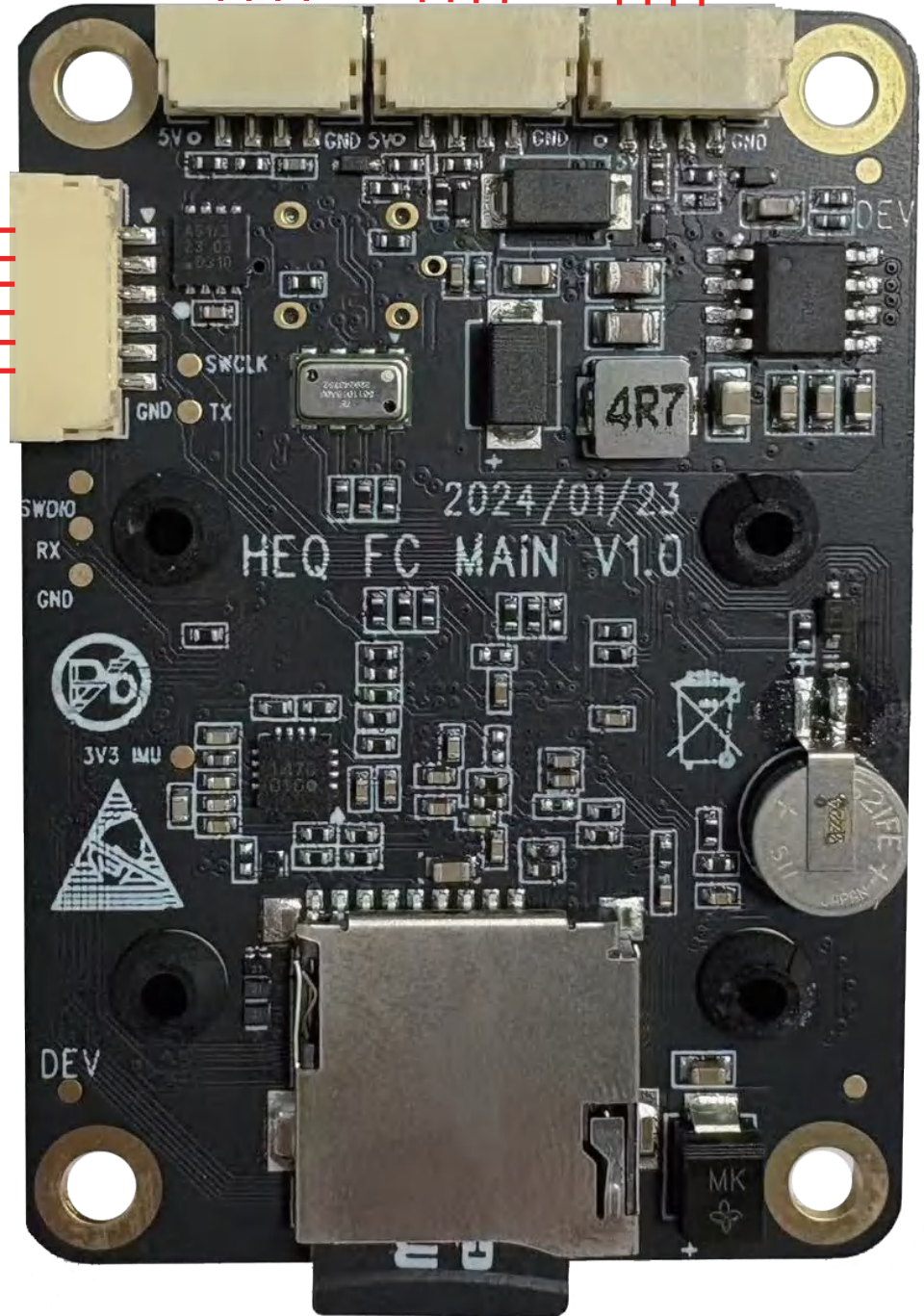

## Flight Guide

### 1. Remote Controller

Currently only supports SBUS protocol. It is recommended to use a remote controller with more than 7 channels to fully utilize the functions of the PNP drone. Our PNP has the function of switching between fixed-wing and rotary-wing, and the mode switching and attitude switching settings can be performed on the remote controller. (For details, please see the video tutorial of the "HEQUAV" Youtube channel). You can use the QGC APP (it is recommended to use QGC on a computer or mobile phone, and using it on a tablet may cause incomplete parameter display) to set the remote control channel (the channel recommendation is as shown below)

|                 |                   | Channel |
|-----------------|-------------------|---------|
|                 | Roll              | 1       |
|                 | Pitch             | 2       |
|                 | Throttle          | 3       |
|                 | Yaw               | 4       |
| Mode switch     | Altitude/Position | 5       |
| Attitude switch | Rotor/Fixed-wing  | 7       |
|                 | Return            | 8       |

### 2. Calibration

Before the aircraft takes off, calibrate the accelerometer, gyroscope, horizon, airspeed meter and compass on the QGC APP. If the absolute value of the airspeed is greater than 5, recalibration is required. If the location is changed, the magnetic compass needs to be recalibrated. If the location environment is not changed, it is not necessary.

### 3. WiFi Connection

(1) Open QGC APP

Note: QGC software is recommended to download the dedicated version from the download center of our official website (Download Center → Rudderless VTOL Flight Platform → Select Swan K1 Pro PNP → Select PC Version/Mobile Version):

<https://www.hequavtech.com/downloads?name=Download+Center&navIndex=4>



(2) Connect the drone's built-in module (please turn on your phone's WiFi)



(3) Return to QGC app



(4) Click the third option



(5) Open the communication connection and click the TCP option



(6) Check Automatically connect at startup and click OK



(7) Return to the QGC interface and wait for the connection to complete

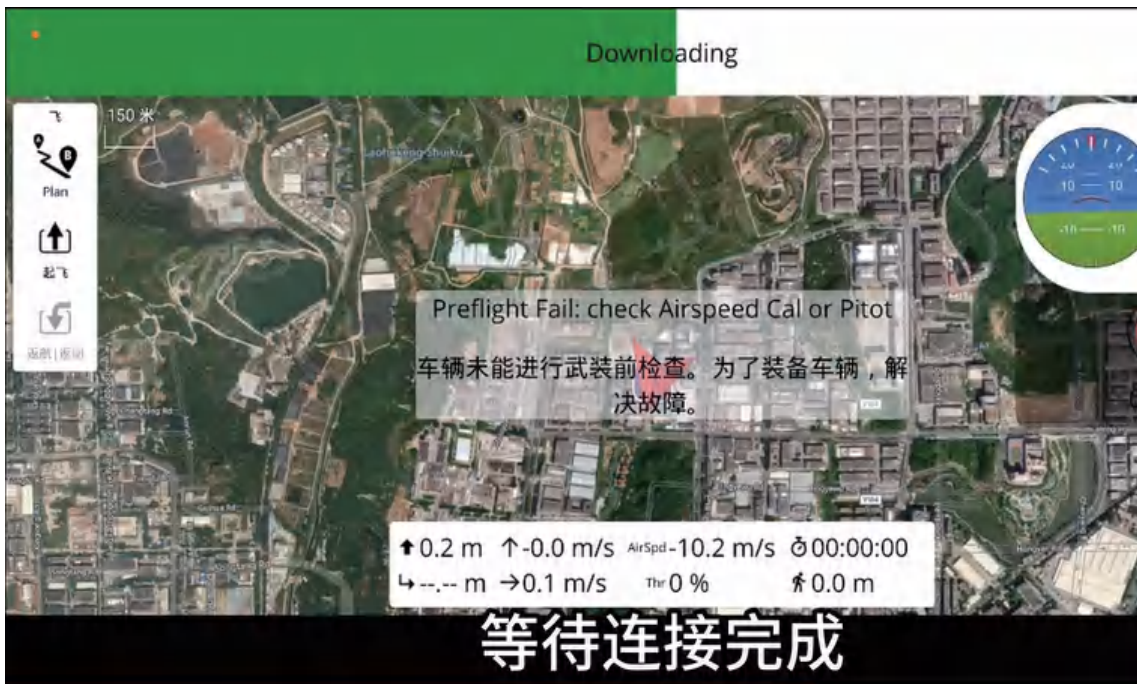

## Pre-Flight Check

1. The joystick of the drone is switched to the position mode. To ensure safety, it is recommended to take off vertically to more than 20 meters before switching to the fixed-wing mode.
2. The drone and remote controller are fully charged.
3. WiFi has been connected and the map has been loaded before flight.
4. GPS signal  $\geq 9$  satellites.

## Notes

1. During takeoff and landing, make sure there are no obstacles around the drone to avoid collision accidents.
2. During the flight, comply with relevant flight regulations, fly in legal areas, and ensure flight safety.
3. During flight, pay attention to the flight attitude and flight altitude of the drone to ensure flight stability.
4. Do not fly in crowds, woods, airports, train stations, buildings, and indoors.

This document is subject to update without prior notice.

You can check the latest version on the HEQ official website <https://www.hequavtech.com/>