

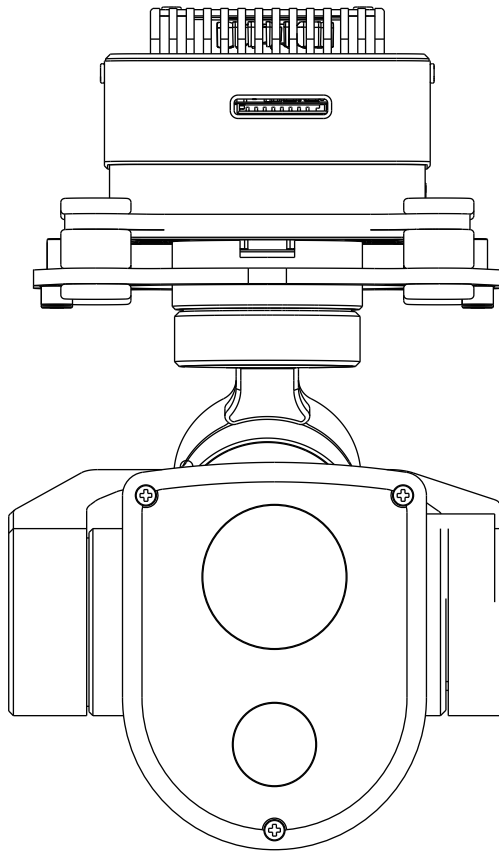

K11 Dual-Sensor Gimbal Camera

Quick Start Guide

V1.0 202606



1. Product Introduction

The K11 is a dual-spectrum gimbal camera specially designed for unmanned platforms. Equipped with dual 48MP visible light lenses, it delivers stable and clear footage, supporting a maximum 160× hybrid zoom. It can observe long-distance targets and capture rich image details simultaneously, greatly improving operational efficiency in inspection, security and other tasks. Built-in AI intelligent recognition and tracking algorithms enable the gimbal to automatically lock dynamic targets such as vehicles and pedestrians, achieving stable follow-up and real-time capture. It is widely applied in security patrol, emergency rescue, industrial inspection and other scenarios, providing efficient and reliable visual solutions for various aerial observation missions.

2. Gimbal External Dimensions (Unit: mm)

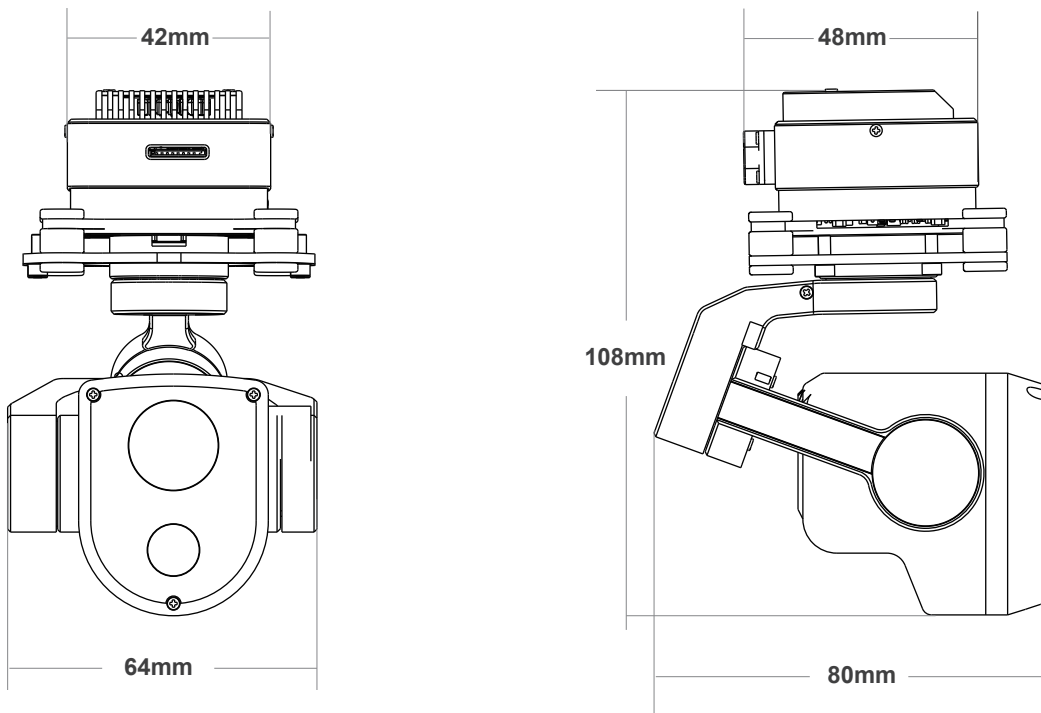

3. Installation Diagram

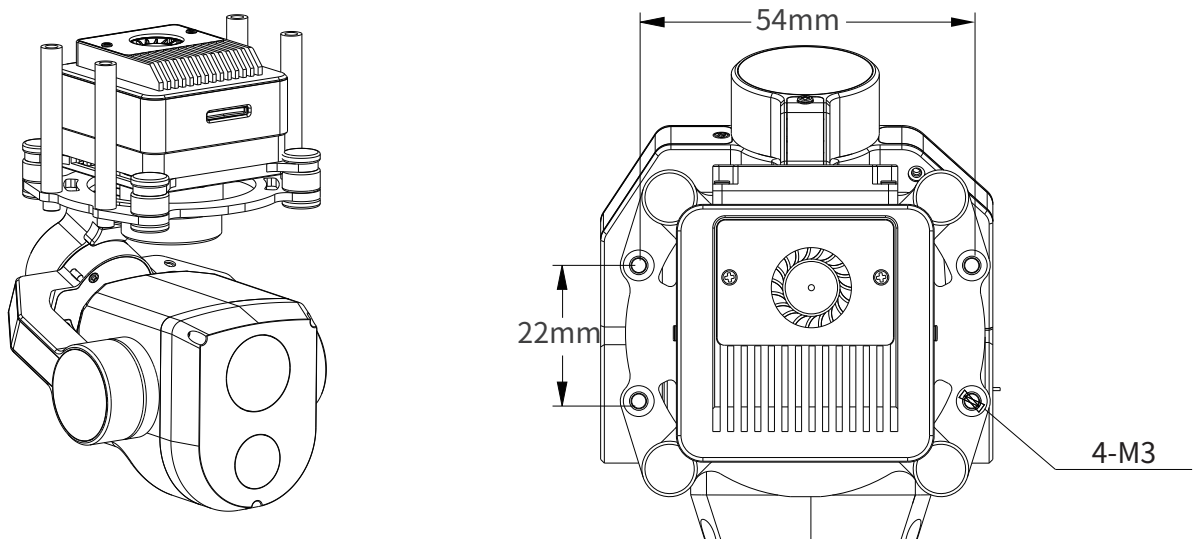

4.Product Hardware Interfaces

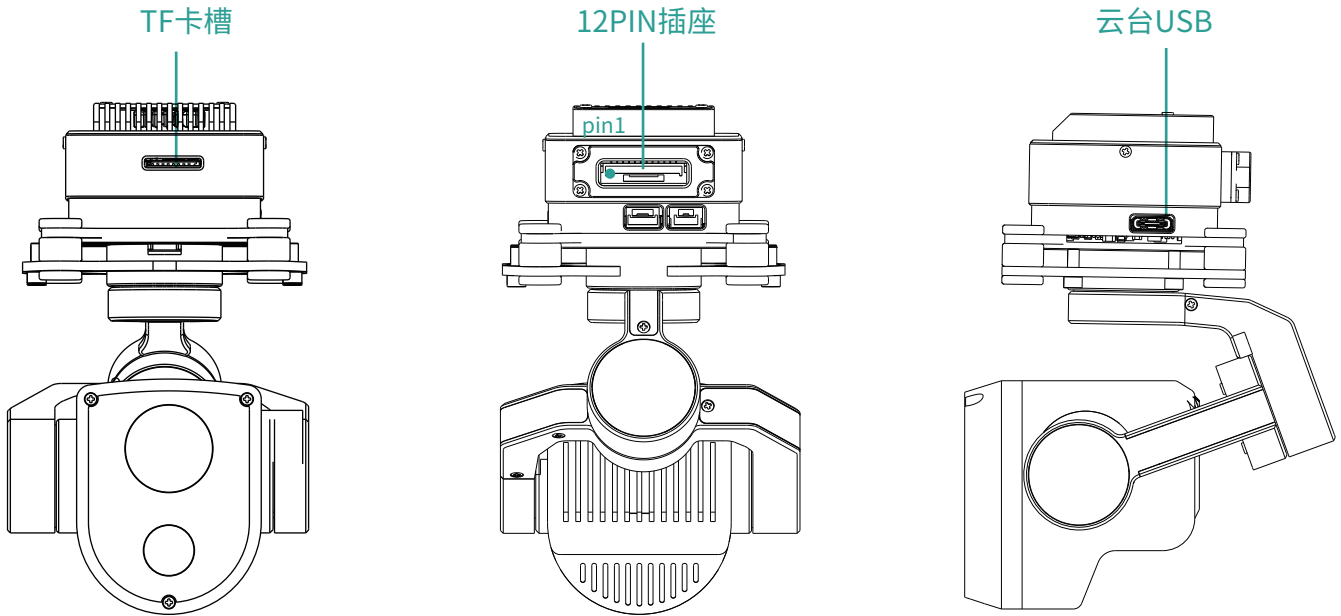

Model	Interface Type	Function
Gimbal USB	USB Port	Gimbal Upgrade Port
Memory Card Interface	TF Card Interface	Store Photos and Videos

No.	Model	Interface Type	Interface Definition	Function
1	12PIN(GH1.25mm) Connector	Power Interface	GND	GND
2		Power Interface	GND	GND
3		Power Interface	12V-18V	Power Input
4		Power Interface	12V-18V	Power Input
5		Communication Interface	T+	Network Interface
6		Communication Interface	T-	Network Interface
7		Communication Interface	R+	Network Interface
8		Communication Interface	R-	Network Interface
9		Communication Interface	SBUS	
10		Communication Interface	GND	
11		Communication Interface	TX	TTL Serial Port
12		Communication Interface	RX	TTL Serial Port

5.Gimbal Camera Parameter List

Weight	195g±5g
Operating Voltage	12V-18V
Number of Axes	3-Axis Mechanical Gimbal
Software Limit Angle	Pitch:-90° to +30° Yaw:-120° to +120°
Mechanical Range	Pitch:-135° to +45° Roll:-45° to +45° Yaw:-135° to +135°
Max Control Speed	180°/S
Angular Vibration Range	±0.005°
Interface	Network Interface/TTL/sbus
Gimbal Mode	Recognition, Auto-Tracking
Operating Temperature	-40℃~+65℃
Communication Protocol	HEQ Proprietary Protocol
Power Consumption	12W
Hybrid Zoom	160x
Optical Zoom	11x
Visual Resolution	48MP(Wide、 Telephoto)
TF Card Photo Format	JPG
TF Card Video Format	MP4
Video Resolution	4K@30fps
Photo Resolution	12MP
Encoding Format	H.264, H.265
AI Recognition & Tracking	Support

Wide-Angle Camera Parameter

Sensor Size	1/2 inch
Focal Length	4.49mm
Effective Pixels	48MP
Aperture	F2.8
FOV (Field of View)	H:71° V:56° D:84°±1°

Telephoto (Zoom) Camera Parameter

Sensor Size	1/2 inch
Effective Pixels	48MP
Focal Length	15.2~50mm
Aperture	F3.7~F4.6
FOV (Field of View)	H:7.4° V:5.6° D:9.3°

6.Product Assistant Software Usage Guide

Please go to the official website "Download Center" to download the assistant software: <https://www.hequavtech.com/>

6.1 Assistant Software Interface

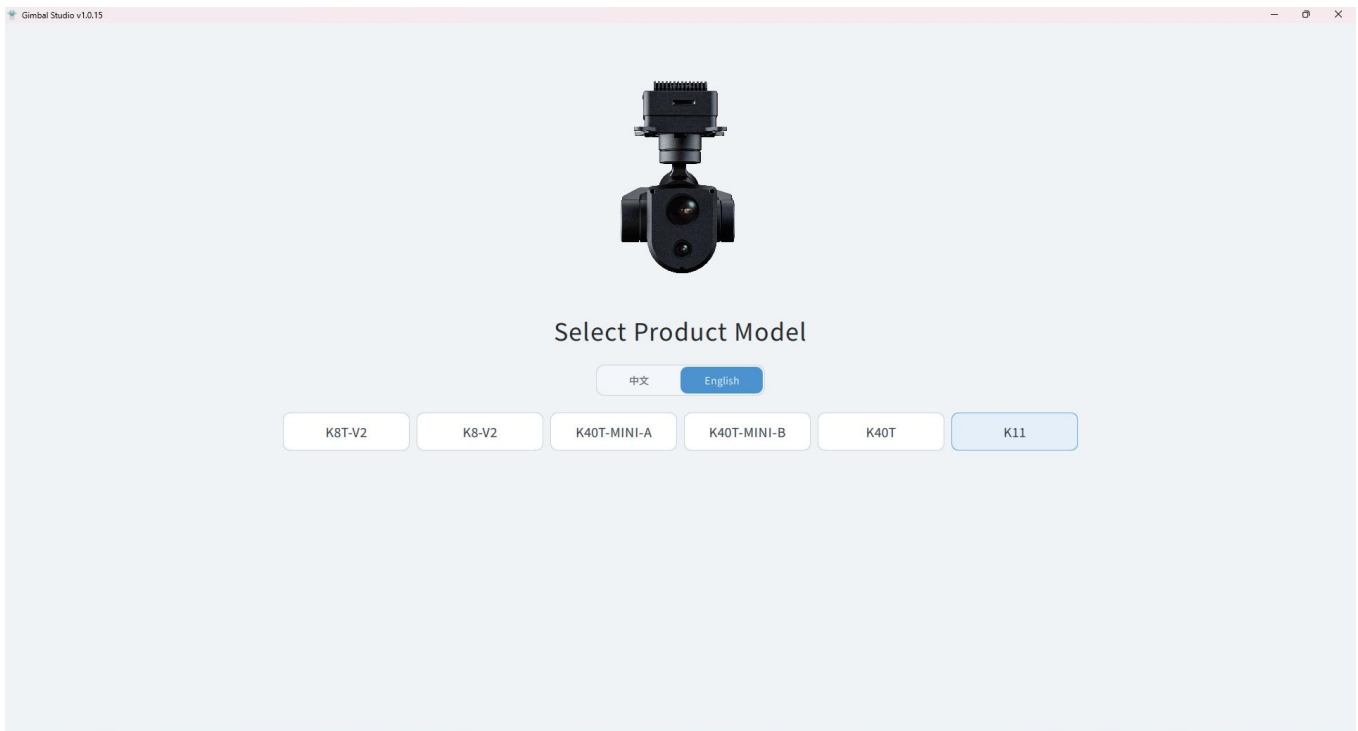

Enter the assistant software page and select the corresponding product model. If you need to switch the language version, please click the icon below to set it.



After entering the page of the corresponding product model, the interface is as follows:

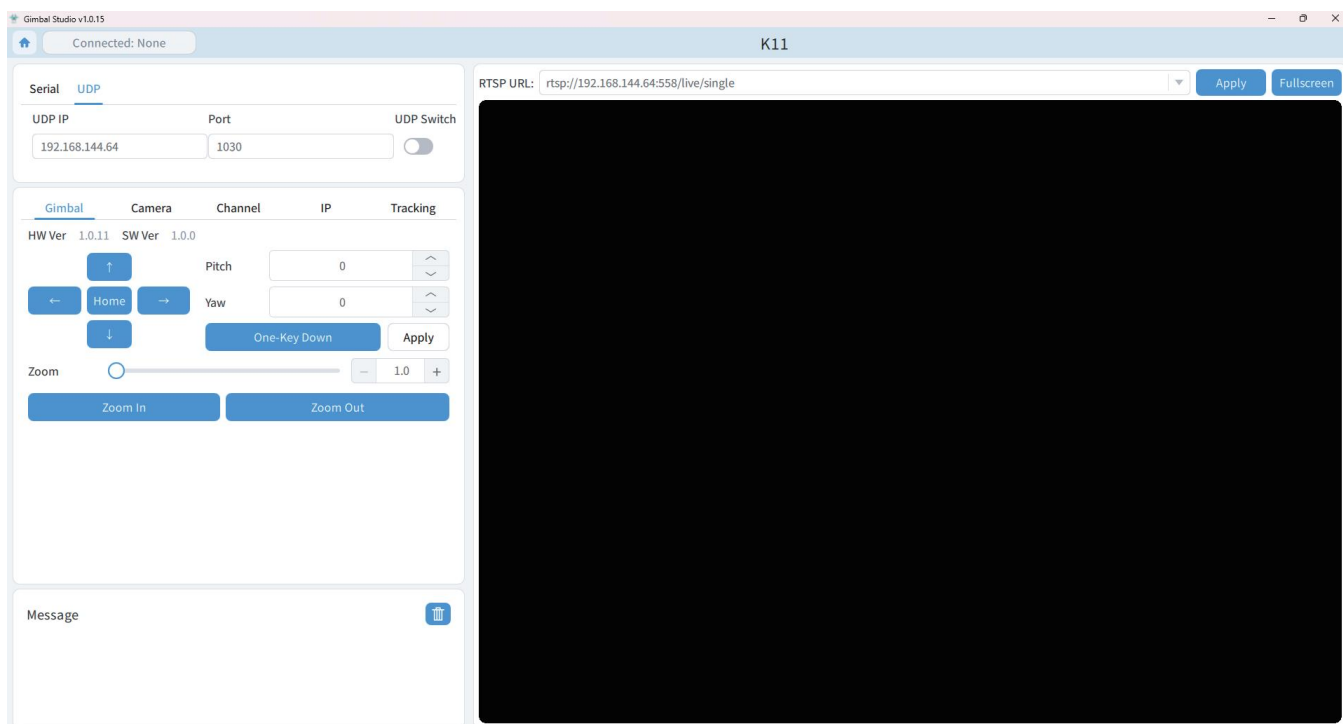

6.2 Connection Settings



Users can choose serial port or UDP connection mode according to actual conditions. For specific parameter settings, refer to the table below:

Interface Type	Parameters/Settings	User Settings Supported Or Not
Serial port baud rate	Default: 115200	NO
UDP address	Default: 192.168.144.119	Yes (IP address)
Video playback address	rtsp://pod IP:558/live/single	Yes (IP address)

6.3 Gimbal Control



Users can click the pan - tilt control buttons to control the pan - tilt's speed and angle. There is an adaptive relationship between the pan - tilt control speed and the zoom ratio; that is, the higher the zoom ratio, the lower the pan - tilt movement speed. In the video output, the zoom is displayed as visible light zoom, and optical zoom, hybrid zoom, and continuous zoom can be realized.

6.4 Video Stream Camera Type Settings

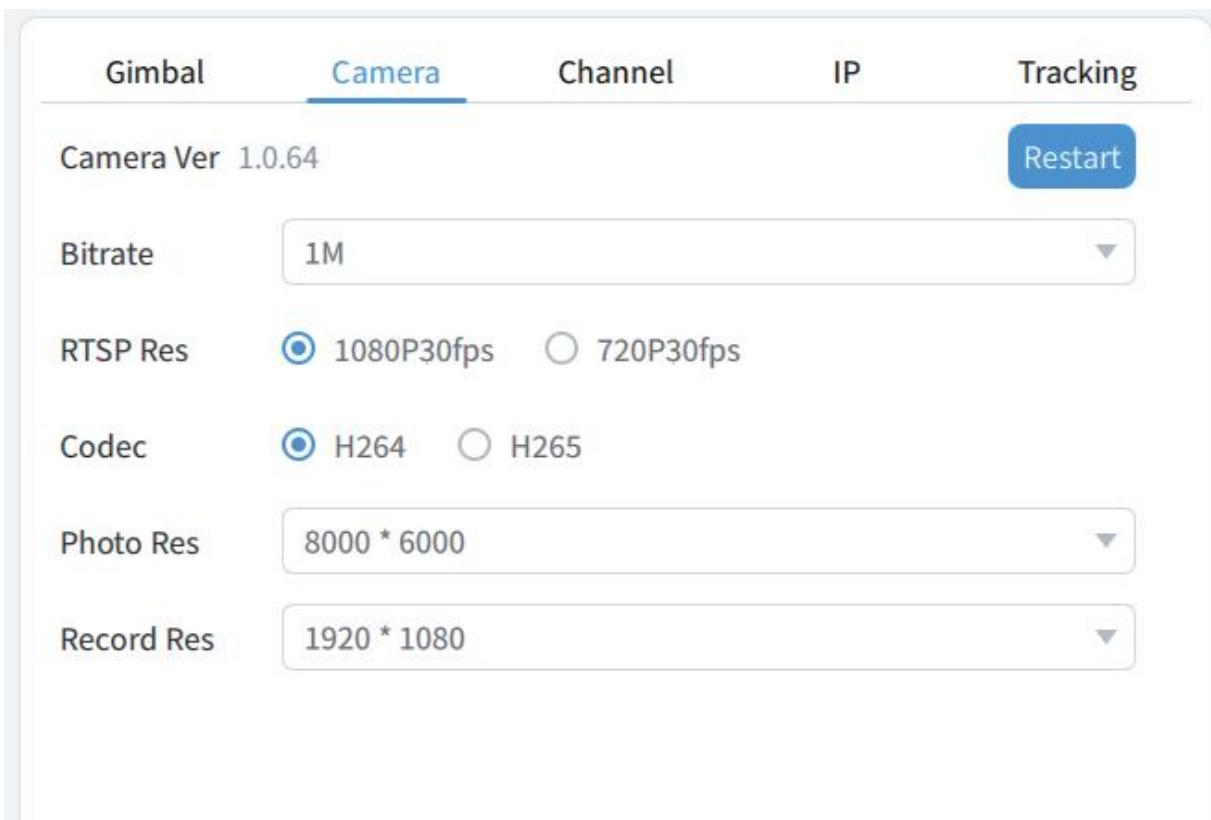

The host computer can select wide-angle or telephoto mode according to actual usage requirements. Users can click the camera restart button to reboot the camera view. It provides switching options for video bitrate, RTSP resolution, video encoding format, as well as photo and recording resolution, which can be selected as needed.

6.5 Sbus Function Settings

Users can customize channel settings for gimbal camera control when using Sbus, as shown in the figure below.

Gimbal	Camera	Channel	IP	Tracking
Channel Mapping				
Stream	CH1	Gimbal Pitch	CH5	
Zoom	CH2	Gimbal Yaw	CH6	
Capture	CH3	Gimbal Home	CH7	
Record	CH4	IR Palette	CH8	
Read			Write	

Channel Value Range

Power cycle required after change

Max	-	1722	+	Min	-	282	+
Read				Apply			

6.6 Camera IP Address Configuration

Gimbal	Camera	Channel	IP	Tracking
IP	<input type="text" value="192"/>	<input type="text" value="168"/>	<input type="text" value="144"/>	<input type="text" value="64"/>
Mask	<input type="text" value="255"/>	<input type="text" value="255"/>	<input type="text" value="255"/>	<input type="text" value="0"/>
Gateway	<input type="text" value="192"/>	<input type="text" value="168"/>	<input type="text" value="144"/>	<input type="text" value="1"/>

Users can configure the IP address according to actual requirements. Note: Please keep a proper record after setting the IP address to prevent connection failure; in the event that the IP address is forgotten, please contact HEQUAV official support for assistance.

6.7 AI Recognition and Tracking Features

Gimbal	Camera	Channel	IP	Tracking
Box Tracking <input type="checkbox"/>	<input type="checkbox"/>	AI Tracking <input type="checkbox"/>		
<input type="checkbox"/> Pedestrian	<input type="checkbox"/>	<input type="checkbox"/> Crowd	<input type="checkbox"/>	<input type="checkbox"/> Bicycle
<input type="checkbox"/> Car	<input type="checkbox"/>	<input type="checkbox"/> Truck	<input type="checkbox"/>	<input type="checkbox"/> Lorry
<input type="checkbox"/> Tricycle	<input type="checkbox"/>	<input type="checkbox"/> Canopy Tricycle	<input type="checkbox"/>	<input type="checkbox"/> Bus
<input type="checkbox"/> Motorcycle				

The K11 features built-in recognition models for common objects such as people, vehicles and provides two distinct tracking modes.

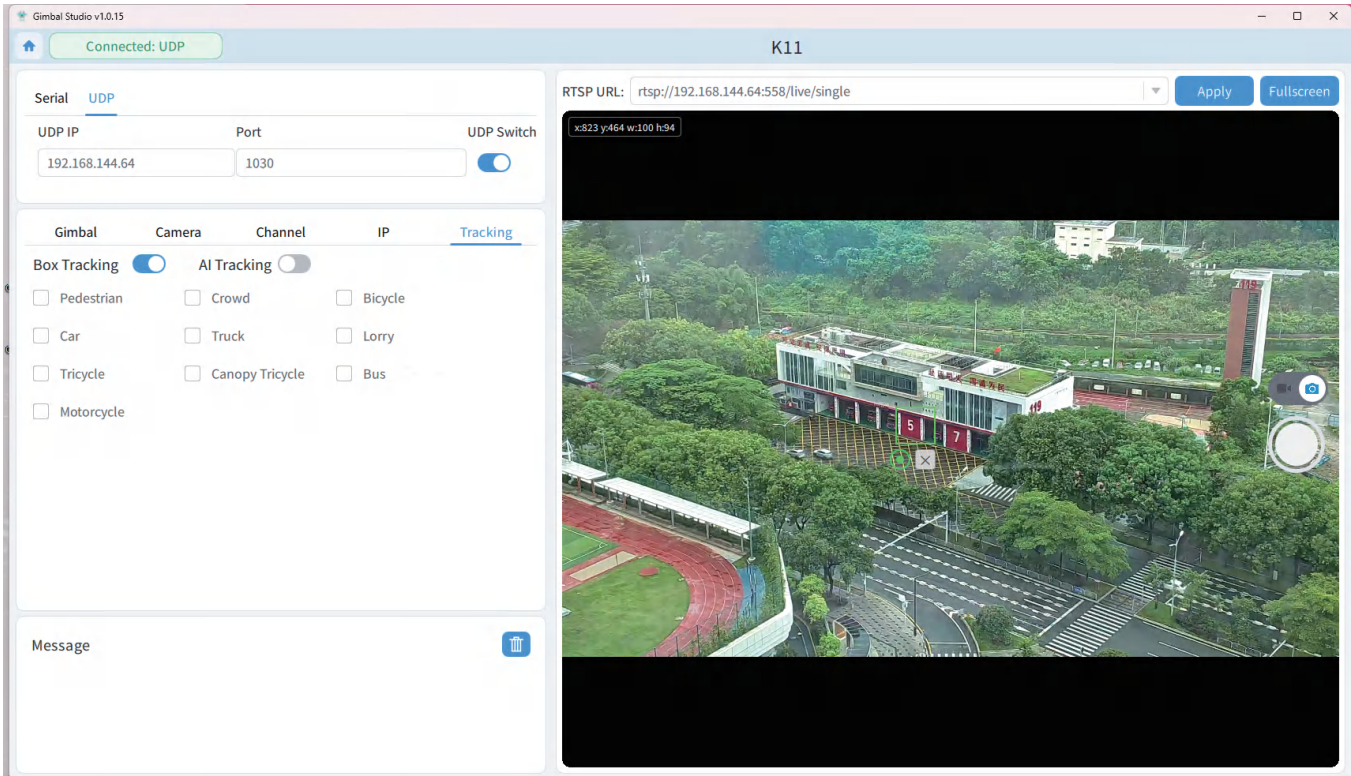

Object Recognition and Tracking: In recognition and tracking mode, identified targets are marked; clicking on the target frame allows entry into tracking mode.

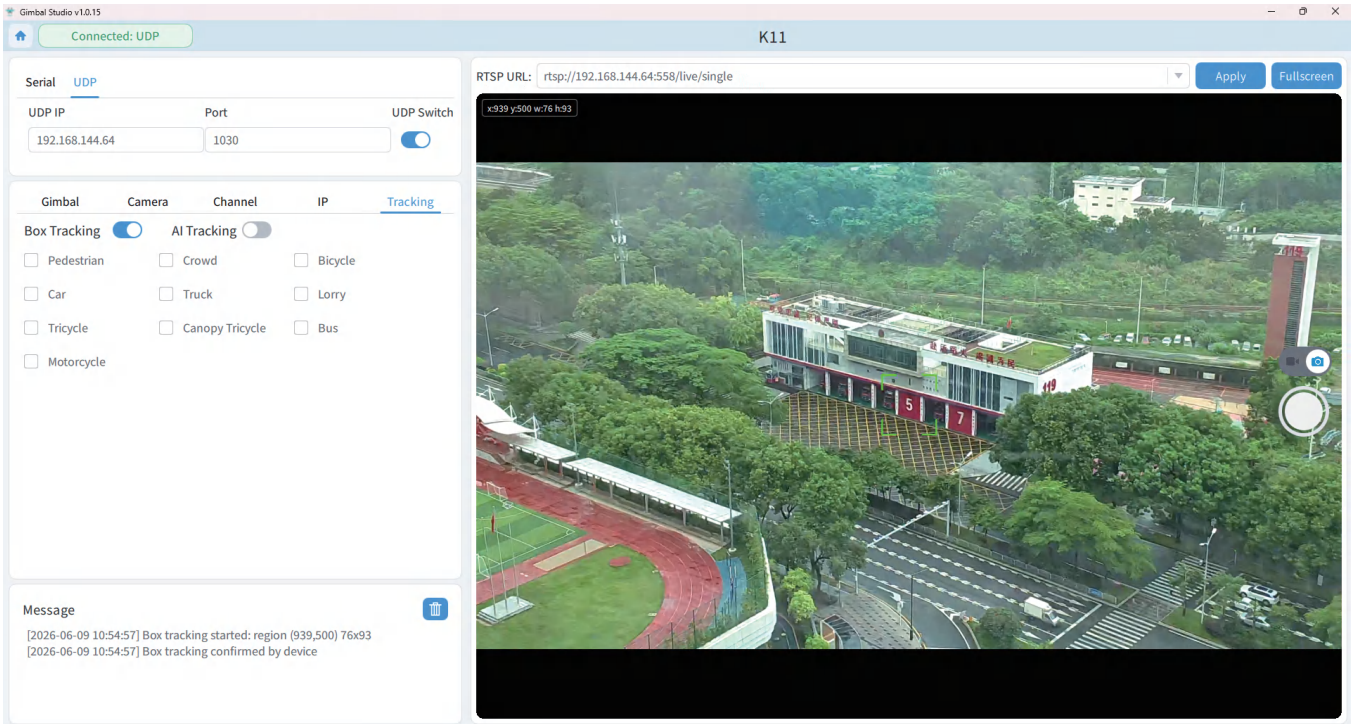

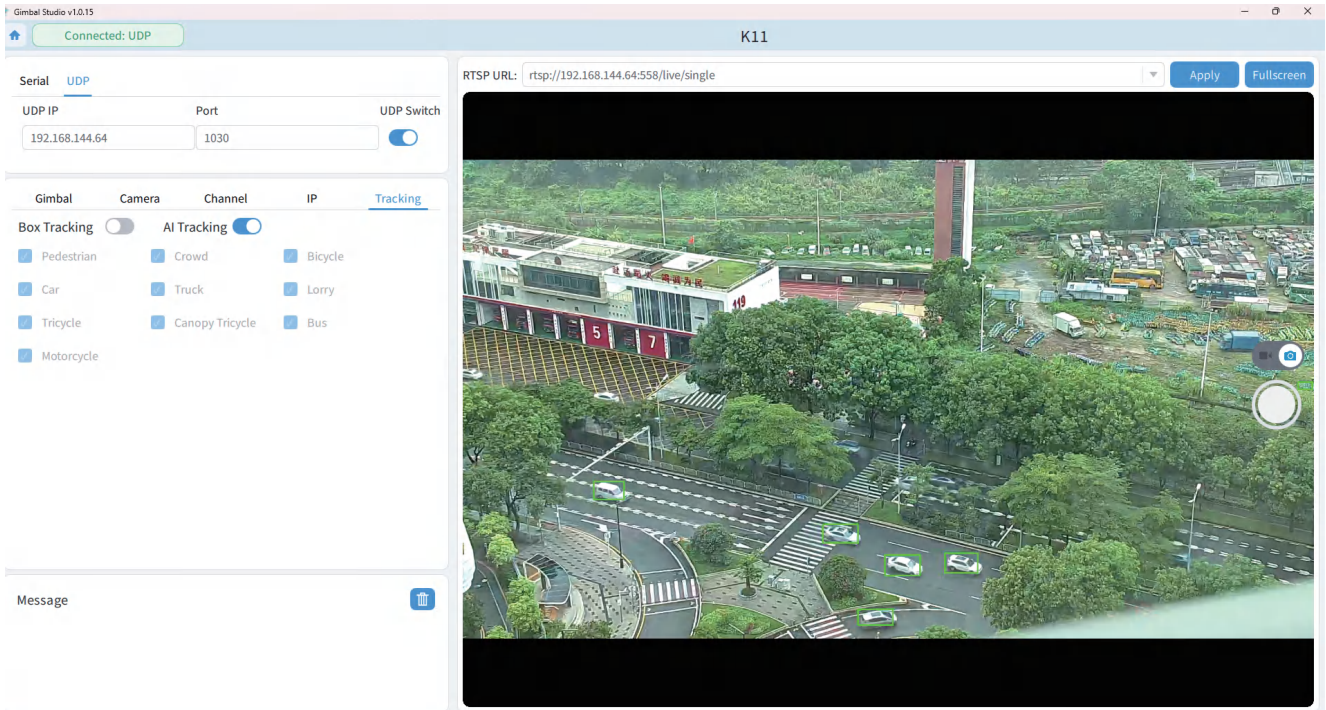

Frame Selection for Tracking: Drag the mouse left button from the top-left corner to the bottom-right corner of the area of interest or target to complete the frame selection. The device will automatically enter tracking mode, and the target will be automatically centered.

After enabling frame selection tracking, the pan-tilt cannot be controlled.

7. Product Firmware Upgrade

The upgrade of the K11 PTZ camera consists of two parts: camera firmware upgrade and PTZ firmware upgrade.

7.1 Camera Firmware Upgrade Method

Place the file in the root directory of the SD card and then power on the device. There is no need to unzip the file; just wait for about 3 minutes.

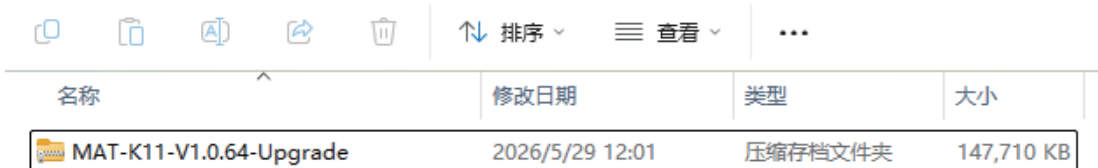

A screenshot of a file explorer interface. At the top, there are icons for copy, paste, print, share, and delete, followed by a sort dropdown menu (排序) and a view dropdown menu (查看). Below these is a table with four columns: 名称 (Name), 修改日期 (Modified Date), 类型 (Type), and 大小 (Size). The table contains one row with the following data: 名称: MAT-K11-V1.0.64-Upgrade, 修改日期: 2026/5/29 12:01, 类型: 压缩存档文件夹 (Compressed Archive Folder), 大小: 147,710 KB.

名称	修改日期	类型	大小
MAT-K11-V1.0.64-Upgrade	2026/5/29 12:01	压缩存档文件夹	147,710 KB

7.2 PTZ Firmware Upgrade Method

Place the file in the root directory of the SD card and then power on the device. During the upgrade, the PTZ motor will be disengaged. After the upgrade is successful, the PTZ will re - self - check and complete stabilization.

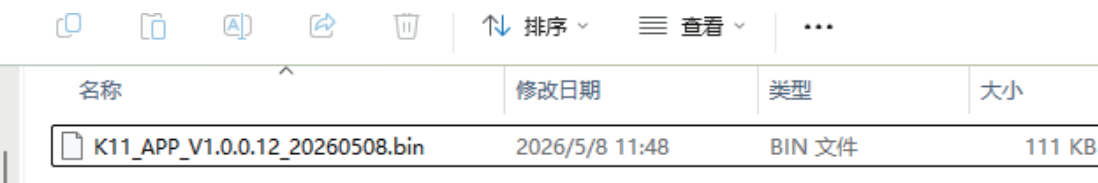

A screenshot of a file explorer interface. At the top, there are icons for copy, paste, print, share, and delete, followed by a sort dropdown menu (排序) and a view dropdown menu (查看). Below these is a table with four columns: 名称 (Name), 修改日期 (Modified Date), 类型 (Type), and 大小 (Size). The table contains one row with the following data: 名称: K11_APP_V1.0.0.12_20260508.bin, 修改日期: 2026/5/8 11:48, 类型: BIN 文件 (BIN File), 大小: 111 KB.

名称	修改日期	类型	大小
K11_APP_V1.0.0.12_20260508.bin	2026/5/8 11:48	BIN 文件	111 KB

8. Usage Precautions

8.1 Storage Environment

Store the gimbal in a cool, dry and well-ventilated place to prevent lens fogging caused by high humidity. Lens fog will dissipate automatically after the device runs for a period of time.

Recommended storage conditions: Temperature $20\pm 5^{\circ}\text{C}$, Relative humidity below 40%.

8.2 Avoid High-Energy Radiation Sources

Do not aim the lens directly at high-energy sources such as the sun, lava or laser beams. The temperature of observed targets shall not exceed 800°C , otherwise the camera will be permanently damaged.

8.3 Avoid High Temperature & Frequent Power Cycles

Do not place the product under direct sunlight, in poorly ventilated areas or near heat sources. Avoid frequent power on/off; wait at least 30 seconds before restarting after power off to extend service life.

8.4 Lens Protection & Cleaning

Do not touch the lens with fingers or hard objects to prevent scratches and image quality loss. Use soft, dry and clean cloth to wipe the lens gently. Do not use alkaline detergents.

8.5 Technical Support

For any questions, please contact Heq official customer service for technical support.

This document is subject to update without prior notice. Please visit the official website <https://www.hequavtech.com/> for the latest version.